



VISUAL INSPECTION MACHINE FOR AMPOULES AND VIALS TYPE RPM100



Features

The visual inspection machine type RPM100 is revolutionary compared to currently available visual inspection machines in the market: CCD cameras are reproducing the real picture of the container magnified by up to 9 times on a colour LCD screen.

The 3 installed cameras allow the reproduction on the screen of up to 6 containers at the same time, giving the operator the possibility to perform comparison between the containers, thus increasing his efficiency as well as reliability by inspection the containers against particles.

The RPM100 is especially designed to handle non stable cylindrical containers, so that a gentle and smooth transport over the processing stations is guaranteed, even at high speed.

A comprehensive list of optional features and accessories allows this machine to be provided to meet the individual requirements of each customer and application.

Standard equipment

- Working range: Ampoules 1 – 30 ml
Vials up 52 mm diameter
- Maximum mechanical speed: 6.000/h
- PLC Elau CodeSys
- Colour LCD screen operator interface
- 3 CCD cameras to allow the inspection of up to 6 objects at the same time, offering a magnifying capability of up to 9 times the real inspection area size
- Inclined infeed belt magazine
- Rotation stations to bring liquid & particles in movement – rotation speed adjustable
- Possibility for rotation repetition
- Rejection magazine for non conform objects
- Outfeed magazine for "good" objects
- One change part set included
- Integrated electrical cabinet
- cGMP compliant

Options

- Infeed/outfeed turn table (only for stable objects)
- Special outfeed magazine adapted to customer tray sizes
- Conveyor belt at infeed/outfeed (only for stable objects)
- Outfeed counter
- Hour meter
- Batch protocol printer
- Validation documentation
- Other options on request



VISUAL INSPECTION MACHINE FOR AMPOULES AND VIALS TYPE RPM100

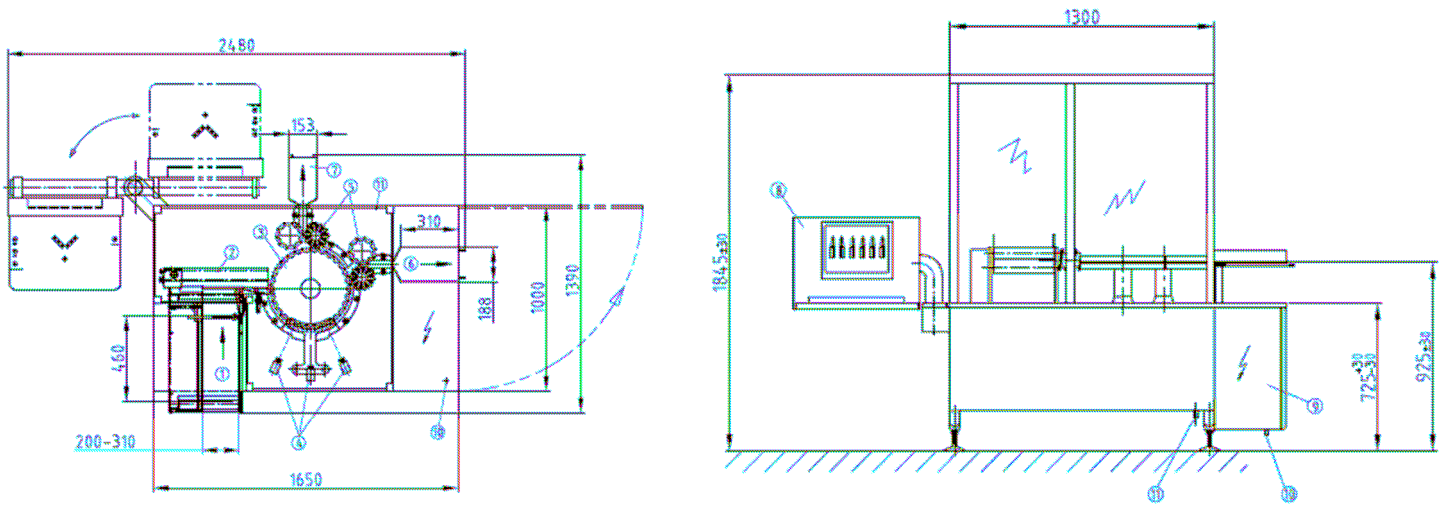

- | | |
|----------------------|-----------------------------------------|
| ① Infeed magazine | ⑥ Outfeed magazine |
| ② Infeed screw | ⑦ Rejection magazine |
| ③ Main star wheel | ⑧ Control screen |
| ④ Camera 3x | ⑨ Electrical cabinet |
| ⑤ Outfeed star wheel | ⑩ Electrical connection 400V 50Hz 3-Ph. |

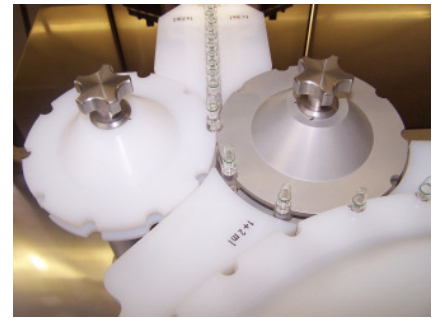

Containers to be inspected are loaded to the infeed magazine from trays. The magazine width is infinitely adjustable from 200 – 310 mm, the length is 460 mm.

The inclined metal belt gently pushes the bunch of containers towards the infeed screw, which separates and transports them to the main star wheel. The transport star wheel hands gradually the containers to the inspection station.

At the inspection stations, the containers are brought into rotation to let the particles move from the bottom and make them twirling inside the liquid.

At the end of spinning, a light from the bottom illuminates the containers revealing the moving particles. The installed cameras are reproducing the real images of containers on the LCD screen, but magnified up to 9 times, depending on the container size. The operator can easily check them against particles and via suitable push buttons decide for their rejection.

Also via a push-button, the operator can decide to repeat the rotation process in case of doubt.

Good containers are collected in an outfeed magazine from which they can be collected into tray.

Rejected containers are deviated by a vacuum intermediary wheel in a rejection magazine.

When handling vials only, the machine can be delivered with conveyor belt at infeed and/or outfeed in order to connect the machine with other processing machines, like labelling machine for example.