



ADELPHI MANUFACTURING

Product Guide



ADELPHI MANUFACTURING

A personal approach, on a global scale

About Us

We are a leading manufacturer of high quality machinery and equipment ranging from washing to filling, capping/closing and liquid inspection. All are made to pharmaceutical and food industry standards, and are suitable for use in manufacturing production areas, laboratories and kitchens, particularly where the highest standards of hygiene are required.

Quality Guarantee

Our customers operate to exacting standards, and our products must meet the highest standards of hygiene and reliability, whatever the production environment. All our products are manufactured from FDA approved materials, and are fully certified where required.

Sustainability

At Adelphi Manufacturing we take our environmental responsibilities very seriously. We strive to ensure that every aspect of our supply chain meets the exacting standards of our environmental policy.

Practical Advice

Our experienced and knowledgeable support team are waiting to help you, and are available Monday to Friday, between 9am and 5pm. They know our product range inside out, so can pinpoint the exact part you need or find the right solution to meet your requirements.

Contents

- 2 Vial Processing**
Filling, Crimping & De-Capping
- 5 Ampoule & Syringe Processing**
Opening, Filling & Sealing of open and closed-type ampoules
- 7 Tube Processing**
Sealing, Trimming & Coding of metal, plastic and/or laminate tubes
- 9 Liquid Inspection**
The pharmacopoeia compliant Apollo range, for particulate detection in transparent and coloured glass containers
- 12 Response Volumetric Fillers**
Versatile, hygienic and scalable; filling machines which grow along with your production requirements
- 18 Capping & Closing**
For press-on, twist-off and ROPP caps

Adelphi Manufacturing

+44 (0)1444 472300

info@adelphi.uk.com

www.adelphi.uk.com

Olympus House · Mill Green Road
Haywards Heath · West Sussex
RH16 1XQ · UK



ADELPHI MANUFACTURING

A personal approach, on a global scale



Established in 1947 as a manufacturer of simple bottle washing and filling equipment for the pharmaceutical industry, Adelphi Manufacturing has grown organically and also through strategic acquisitions, to become a global business exporting laboratory equipment to over 90 countries around the world.

ISO 9001:2015 certification guarantees the quality of our processes and procedures, and our award-winning team manufacture products to meet GMP requirements, as well as European and US quality standards.

This Product Guide demonstrates our hygienic, high quality solutions for companies in the Pharmaceutical & Research Laboratory, Cosmetics & Personal Care, Food & Beverage, E-Liquid & CBD, Veterinary and Chemical industries. Our portfolio includes equipment for the washing, filling, capping/sealing and inspection of bottles, tubes, jars, tubs, vials, ampoules and syringes.

The Adelphi Group of Companies is family owned and managed, and this will continue on to the next generation. Continuity of ownership has given our team a stability that is highly valued by suppliers, staff and customers alike. Many of our relationships date back over decades, and are built on mutual respect and trust.

Whilst our global distribution footprint is increasing exponentially, our operations will always remain true to these values we share with our customers.

Chris Wilson
Managing Director, Adelphi Group of Companies



Adelphi offers a range of equipment designed to facilitate the efficient filling, closing and inspecting of vials in a laboratory or R&D environment.

XYZ Distributor

The XYZ Distributor is designed to be used in conjunction with the Accuramatic Peristaltic Dispenser (below), and enables vials, bottles and ampoules to be filled automatically in trays. The Z axis is the diving nozzle movement that allows liquid to be automatically filled from above the neck or into the neck.

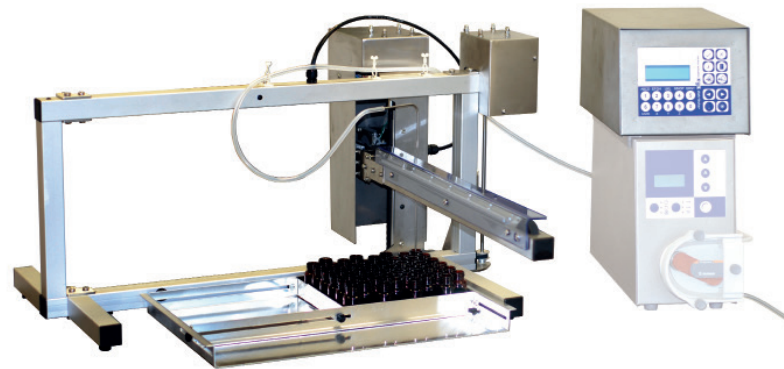

| Item code | Specification |
|------------------------------|--|
| 3525000 | XYZ DISTRIBUTOR |
| Electricity (selectable) | 240V AC, 50/60 Hz, 500 W (120V optional) |
| Movement space (mm) | X = 520, Y= 335, Z= 155 |
| Electronics | Mircoprocessor |
| Weight (kg) | Control: 4.5. XYZ: 9.0 |
| Dimensions distribution (mm) | 790 × 625 × 390 |
| Control dimensions (mm) | 200 × 280 × 180 |
| Drip delay | 0.0–0.9 secs |
| Max vial height (mm) | 200 |
| Min neck opening (mm) | 8 |
| Tray fill area (mm) | 410 × 265 |

Key Features:

- Control box remote from moving nozzle frame suitable for use in laminar flow cabinet
- Adjustable trays are supplied so that bottles are held in an orderly fashion
- Setting up is easy using the menu-driven LCD displays
- Special trays can be made to suit odd shaped bottles
- Fills straight rows or honeycombed configurations

Accuramatic Peristaltic Dispensing Unit

This unit can be operated by hand, foot switch, or will cycle automatically with a delay of up to 10 seconds between fills. The pump runs at a constant speed for a precisely determined period of up to 100 seconds, can run forwards or backwards, and has a choice of three filling modes: Braked stop – Soft stop – Stop with suck back.

Like all peristaltic pumps the liquid only comes into contact with the inside of one uninterrupted length of silicone tubing, which will withstand repeated

sterilisation. Bacteriological inline filtration can be performed at the outlet side of the pump. This Peristaltic Dispenser can be combined with our XYZ Distributor to offer quick, easy and hygienic filling of whole trays of vials or bottles automatically, or with our filling jig for filling small numbers of ampoules.

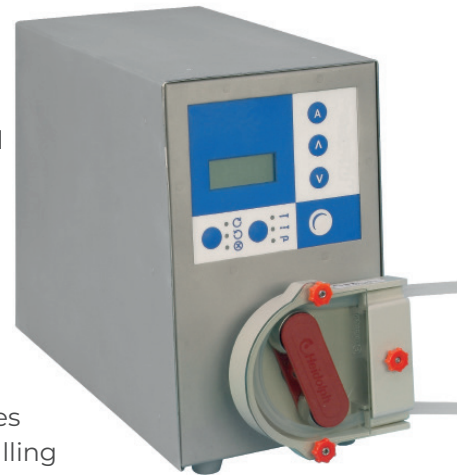

The Peristaltic Dispenser can be supplied with a range of sizes of high strength silicone tubing from 0.8mm bore to 8mm bore, with either a 1.6mm or 2mm wall thickness.

Please ask for further details on the size to best suit your requirements.

| Item code | Specification |
|--------------------|---|
| 3510000 | PERISTALTIC DISPENSER |
| Volumes (ml) | 1 to 1,000 |
| Repeatability | ± 0.5% |
| Max flow rate (ml) | 36 ml/sec (standard pump. Twin pump option available) |
| Electricity | 240V AC, 50 Hz, 50 W (120V optional) |
| Weight (kg) | Nett 8.5, Gross 10.5 |
| Carton size (cm) | 44 × 23 × 43 |

Powered Vial Crimper

An air operated Power Crimper with stand and foot pedal and interchangeable screw-in heads.

The unit gives fast and reliable crimping or decapping and reduces operator fatigue. The stand is made from stainless steel and the crimping unit - which may be used separately - is of corrosion resistant nickel electro plate.



| Item code | Specification |
|-----------------|------------------------------------|
| 6030500 | POWERED VIAL CRIMPER |
| Length (mm) | 370 |
| Width (mm) | 230 |
| Height (mm) | 420 |
| Weight (kg) | Operational: 9.85, Shipping: 10.40 |
| Air | at 4 bar |
| 6030501S | BENCH STAND |
| 6030502 | FOOT PEDAL |

| Item code | Specification |
|----------------|---|
| 6030503 | 13mm crimping head for plain seals |
| 6030504 | 13mm crimping head for flip-off seals |
| 6030505 | 20mm crimping head for plain seals |
| 6030506 | 20mm crimping head for flip-off seals |
| 6030507 | 13mm decapping head for plain seals |
| 6030508 | 13mm decapping head for flip-off seals |
| 6030509 | 20mm decapping head for plain seals |
| 6030510 | 20mm decapping head for flip-off seals |
| 6030514 | 20mm crimping head for flip tear-up seals |

All crimping and decapping heads are interchangeable between the manual and powered crimping units

Note: other head sizes are available. Please ask for further details.

Manual Vial Crimper

This benchtop Vial Crimper provides a manual alternative to hand crimping and decapping operations. Unit height and position are adjustable to accommodate a variety of vial sizes allowing the operator to work in a comfortable position. The unit is manufactured from stainless steel. Heads are quickly and easily changed without the use of tools since they simply screw in and out.

All crimping and decapping heads are interchangeable with the Powered Vial Crimper.



| Item code | Specification |
|-------------------------|---------------------------------------|
| 6030555-1 | MANUAL VIAL CRIMPER WITH STAND |
| Length (mm) | 305 |
| Width (mm) | 254 |
| Height (mm) | 457 |
| Operational weight (kg) | 9.5 |

Crimping and Decapping Tongs



Hand Crimping Tongs (A)

Fitted with hardened steel jaws for long life and reproducibility of seal crimp quality. There is an adjustable stop to ensure that equal pressure is supplied to each crimp.

| Item code | Size* |
|-----------|--------------------------|
| 6030613 | 13 mm plain seals |
| 6030614 | 13 mm flip-off seals |
| 6030620 | 20 mm plain seals |
| 6030621 | 20 mm flip-off seals |
| 6030622 | 20 mm flip tear-up seals |

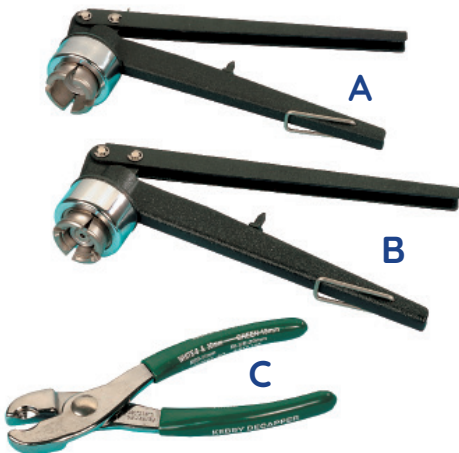

Hand Decapping Tongs (B)

With hardened steel jaws for the easy removal of crimp top seals, by squeezing the handles together.

| Item code | Size* |
|-----------|-------------|
| 6030722 | 13 mm seals |
| 6030721 | 20 mm seals |

Hand Decapping Pliers (C)

For removing seals from vials with a press and wrench action. The handles are plastic coated.

| Item code | Size* |
|-----------|-------------|
| 6030713 | 13 mm seals |
| 6030720 | 20 mm seals |

* Other sizes available upon request.

Vial Processing – Production

If your requirements stretch beyond the abilities of manual or semi-automatic equipment, Adelphi is able to supply fully automatic vial processing machinery. As the sole UK representative of ROTA since 1976, Adelphi can offer expert advice, and reliable servicing and spares support.

Please see our 'Ampoule and vial Processing – Production' data sheet, or our website for further information.

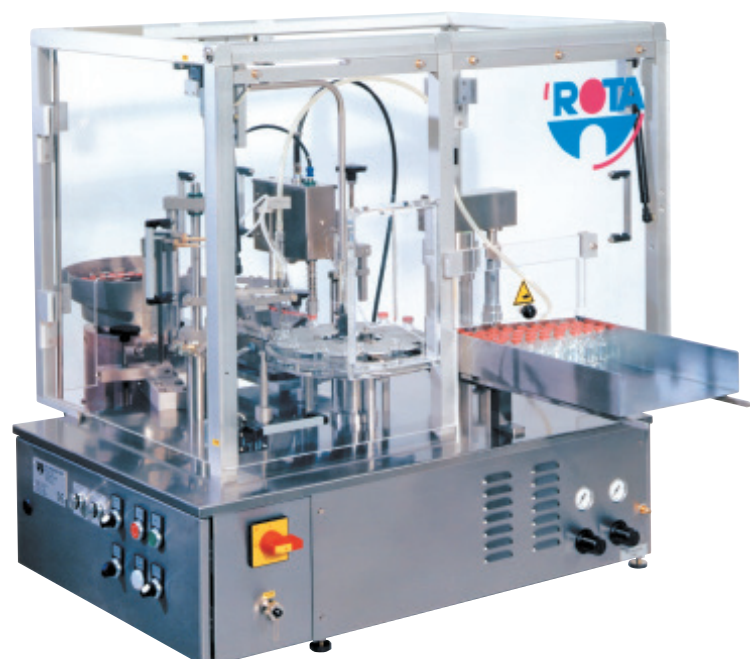



AMPOULE & SYRINGE PROCESSING

A range of equipment designed to facilitate the efficient opening, filling, closing and inspecting of ampoules in a laboratory or R&D environment.

OC Ampoule Opener & Sealer

Ideally suited to small-scale producers and R&D laboratories, where closed ampoules are used to obviate the need for internal washing.

Opening Ampoules: A flame of mixed gas and oxygen is applied to melt the glass. As the flame approaches the glass, an electric switch is thrown and the chuck rotates. When the opening station is in use, the ampoule is opened with the flame.

Ampoules are then filled using Adelphi's Accuramatic Peristaltic Dispenser and Filling Jig (below).

Closing Ampoules: Gripper jaws are placed onto the ampoule neck and the flame is applied. As the glass becomes plastic, the counterweight pulling on the jaws draws off the ampoule neck and a perfect rounded finish is achieved with very little practice.

The sealing process is quick and produces closed ampoules of equal quality to an automatic machine. Although designed to open and close closed type ampoules, this versatile machine will also handle open type ampoules after washing.

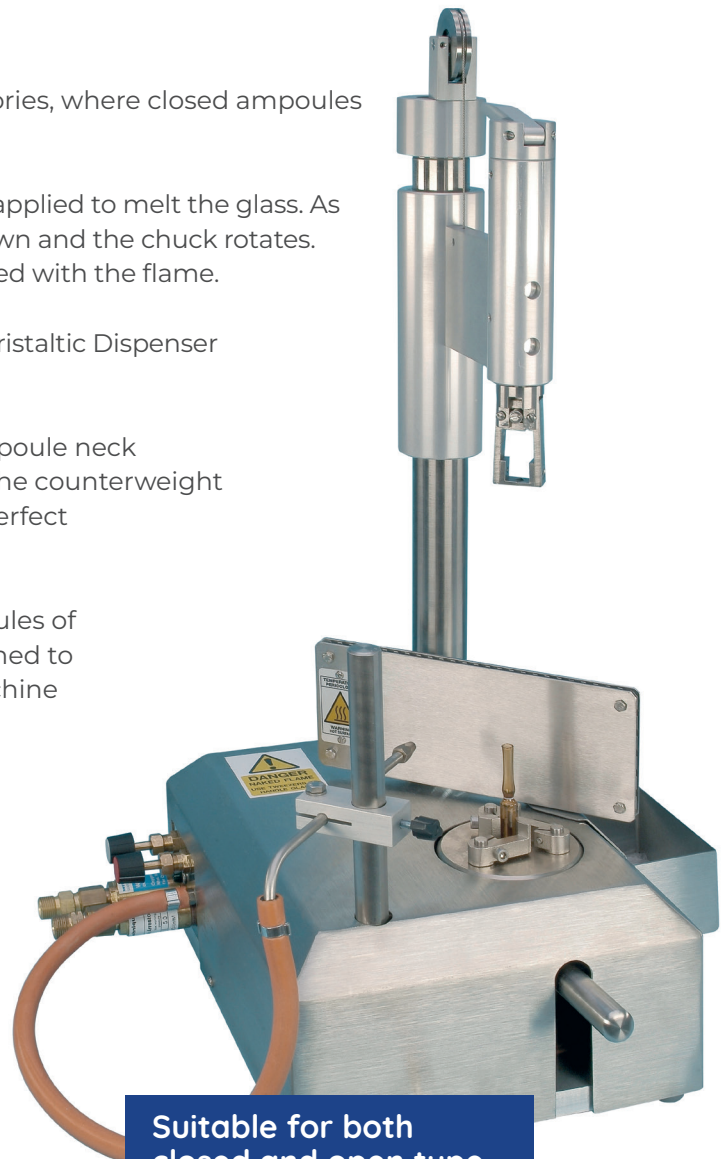

Suitable for both closed and open type ampoules; output of 600 per hour

| Item code | Specification |
|-------------------|---------------------------------------|
| 6035000 | OC AMPOULE PROCESSING MACHINE |
| Ampoule Size (ml) | 1-50 open or closed |
| Output | Approximately 600 per hour |
| Length (mm) | 380 |
| Width (mm) | 400 |
| Height (mm) | 660 |
| Weight (kg) | Operational: 22, Shipping: 46 |
| Crate size (cm) | 49 x 44 x 85 |
| Electricity | 240V AC, 50 Hz, 200 W (120V optional) |
| Gas | Natural gas or propane at 0.5 bar |
| Oxygen | Standard commercial supply at 1 bar |

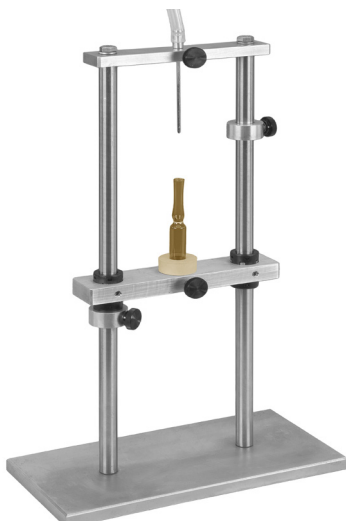

Filling Jig

A useful hand operated accessory for use with the Accuramatic Peristaltic Dispenser, designed to ensure the clean filling of small necked containers such as ampoules without wetting the wall of the container where it is to be sealed. The container is placed in a custom-made holder and raised by hand to a predetermined stop when the needle will be centred inside the container.

| Item code | Specification |
|-------------------|--------------------|
| 3510090 | FILLING JIG |
| Overall Size (mm) | 210 x 105 x 345 |
| Weight (kg) | 2.8 |



Twin-Jet Ampoule Sealer

This hand operated unit is designed for use with natural or bottled gas and air. A mixer valve enables the user to adjust the flame for optimum heat. A small air pump is available for situations where compressed air is not available. A pressure regulator/gauge is recommended to keep the flow constant with a compressed air supply.

The ampoule is placed and held on the adjustable platform and turned while manually drawing off the ampoule top with tweezers.

| Item code | Specification |
|-------------------|---|
| 6002100 | TWIN-JET AMPOULE SEALER |
| Ampoule Size (ml) | 1-50 open type |
| Output | up to 120 per hour |
| Length (mm) | 125 |
| Width (mm) | 210 |
| Height (mm) | 280 |
| Weight (kg) | Nett: 1.86 (excl. air compressor), Gross: 2.4 |
| Electricity | 240 V AC, 50 Hz, (120 V optional) to power air compressor (if required) |
| Gas | Natural gas supply or bottled butane or propane gas at 0.5 bar |
| Air | Compressed air at 1 bar (optional compressor supplied) |
| Carton size (cm) | 35 x 31 x 17 |
| 6002110 | PRESSURE REGULATOR/GAUGE |
| 6002119 | AIR PUMP |



Syringe Stopper Press

The Adelphi Syringe Stopper Press comprises a syringe holding jig, lever operated stopper press, and a divide for aiding the removal of air from the syringe. All contact parts are manufactured from 316L grade stainless steel.

This product enables the user to easily and efficiently insert stoppers in to pre-filled syringes whilst ensuring that all air is expelled. The unit is fully adjustable and can accommodate glass or plastic syringes of 6.35mm bore or greater.

A range of equipment designed to facilitate the efficient filling and closing of tubes in a laboratory or R&D environment.

Vesta 1C – Plastic/Laminate Tube Sealer

Compact and robust in a stainless steel case with clear, simple controls, the Vesta 1C offers a low maintenance tube closing solution, ideal for small batch production. The unit has been designed for laboratory sealing and small production runs of plastic or laminate tubes, which are sealed, trimmed and coded.

| Item code | Specification |
|-------------------------|---|
| 3140001 | VESTA 1C TUBE SEALER |
| Tube seal range | 10–50 mm diameter |
| Output (per minute) | Up to 4 |
| Electricity | 240 V AC, 50/60 Hz, 500 W (120V optional) |
| Air supply (per minute) | 20 litres at 6 Bar |
| Overall size | 400 × 345 × 700 mm |
| Weight | 31kg |
| 31406 | PAIR OF BESPOKE TUBE CUPS FOR EACH TUBE SIZE |
| 3140601 | SET OF NUMERALS 0 – 9 (L-SHAPED) |
| 3140601-A-Z | LETTERS AND NUMBERS (L-SHAPED) |



Centrac FCC – Metal Tube Closer

Designed to close collapsible metal tubes, the Centrac FCC is operated by a handle, which requires two turns to close, fold and crimp the tube giving a double fold. An adjustable rest is provided to locate tubes in the correct position, a gauge plate regulates the depth of fold required, and a wing nut adjusts the depth of crimp.

All working parts are fully guarded. The angle of operation is infinitely variable through 90°. Coding jaws are supplied as standard to hold up to 4 figures and/or letters for batch marking.

| Item code | Specification |
|--------------------------------------|-------------------------------------|
| 3101000 | CENTRAC FCC TUBE CLOSER |
| Output (per minute) | Up to 10 |
| Tube diameters | From 12 mm to 40 mm |
| Depth of base in vertical position | 203mm |
| Depth of base in horizontal position | 267 mm |
| Width of base | 191mm |
| Width of handle | 330 mm |
| Height in vertical position | 308mm |
| Height in horizontal position | 267 mm |
| Weight | 11.6 kg |
| 3110000 | NUMERALS 0-9 FOR CODING JAWS |
| 311001-26 | LETTERS A-Z FOR CODING JAWS |



Tube Folding Pliers

These Tube Folding Pliers provide a simple method of reliably closing individual metal tubes. They are hand held with plastic handles for comfort and safety.

Suitable for tube diameters 12 - 40mm.

| Item code | Specification |
|------------------------------------|----------------------------|
| 4001100 | TUBE CLOSING PLIERS |
| Output (per minute) | Up to 10 |
| Tube diameters | From 12mm to 40mm |
| Depth of base in vertical position | 203 mm |
| Weight | 300 gm |



Tube Processing – Production

If your requirements stretch beyond the abilities of manual or semi-automatic equipment, Adelphi is able to supply fully automatic tube processing machinery. As the sole UK representative of TGM since 1995, Adelphi can offer expert technical sales advice, and reliable servicing and spares support.

Please see our 'Tube Processing – Production' data sheet, or our website for further information.



Adelphi's Apollo Liquid Viewers offer a simple yet effective method of detecting particulate matter unintentionally present in liquids.

Apollo I Liquid Inspection Unit

Designed for use in pharmaceutical and laboratory environments, the Apollo I Liquid Viewer has a polarised inspection light for the detection of particulate matter in transparent liquids contained in ampoules, vials and bottles. Particulate contamination can be unintentionally present in injections and intravenous infusions, and this unit provides a simple method of detection.

To operate, simply hold the container between the light panel and the polarising screen, shake or swirl the container, and any particles will show as bright specks against a dark background.

1.7 x
Magnification



Key Features:

- Compact and hygienic stainless steel body
- Adjustable viewing angle to suit individual working preferences
- Adjustable magnifier
- LED light source for optimum bulb life
- Tool free assembly
- Offers a clear, polarised and magnified image

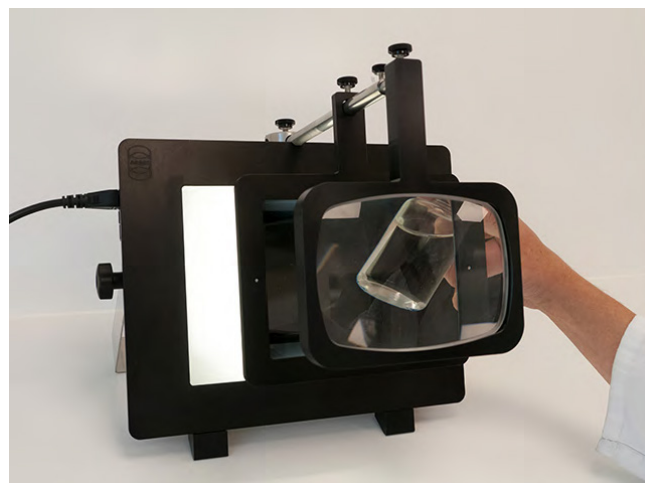

| Item code | Specification |
|-------------------|------------------------|
| 6031301 | APOLLO I LIQUID VIEWER |
| Length (mm) | 320 |
| Width (mm) | 295 |
| Height (mm) | 420 (max) |
| Weight (kg) | Nett: 4.9 Gross: 7.2 |
| Carton size (cm): | 50 x 41 x 27 |
| Electricity: | 110/240V AC 50/60HZ |

"I recently ordered the Apollo I Liquid Viewer and was dependent on the delivery arriving in Switzerland within a few days. The employees were extremely helpful and reliable. Within a week the delivery was completed and the box was ready for use. The quality of the box is also top notch and allows particles to be seen as reliably as possible. Thanks a lot! Until the next order."

InnoMedica Holdings AG

Apollo II Liquid Inspection Unit (for transparent glass)

Designed for use in pharmaceutical and laboratory environments, the Apollo II Liquid Viewer provides a simple method for the detection of visible particles in ampoules, vials, and bottles.

The unit is operated by simply swirling each individual container in front of both panels, and observing for any particulate contamination (other than air bubbles) unintentionally present in the solution. In front of the black panel, light coloured particulates will be visible, and in front of the white panel, dark coloured particulates will be visible.



Conforms to the European Pharmacopoeia Specification 2.9.20 and to the US Pharmacopoeia USP chapter 41, section 6.1.

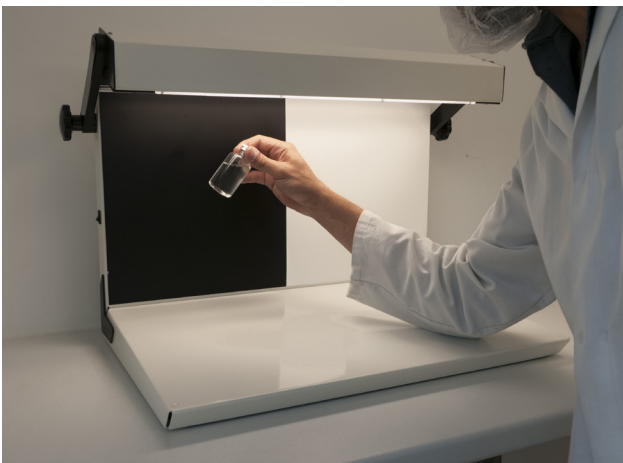

Key Features:

- Adjustable lamp unit for comfortable working height
- Uses two energy efficient LED lamps
- Fold up frame for space saving and easy storage - the inspection surfaces fold together to reduce the chance of damage
- Removable diffuser for 'informal' use with coloured glass
- Conforms to European Pharmacopoeia 2.9.20 and to the US Pharmacopoeia – USP chapter 41, section 6.1
- Intuitive assembly with no tools required

| Item code | Specification |
|-------------------|--------------------------------|
| 6031511 | APOLLO II LIQUID VIEWER |
| Length (mm) | 714 |
| Width (mm) | 420 |
| Height (mm) | 450 |
| Weight (kg) | Nett: 10 Gross: 7.9 |
| Carton size (cm): | 76 x 52.5 x 26.5 |
| Electricity: | 100/240V AC 50/60HZ |



Supporting IQ/OQ documentation can be supplied upon request.

User manuals are available in English, Spanish, French, German, Dutch & Czech – additional languages are also available upon request.



Apollo II High Intensity Liquid Inspection Unit (for coloured glass)

The Apollo II High Intensity specification is ideal for coloured glass containers. It uses an updated three LED bulbs, giving a light level of 8,000 – 10,000 lux.

This unit also conforms to the European Pharmacopoeia Specification 2.9.20 and to the US Pharmacopoeia – USP chapter 41, section 6.1.



Supporting IQ/OQ documentation can be supplied upon request.



“The Apollo II Liquid Viewers are a very cost-effective and reliable [solution], as well as compliant to US compendia. Great product!”

PharmEng Technology, Inc



RESPONSE VOLUMETRIC FILLERS

Adelphi manufactures the highly regarded Response range of hygienic, versatile and scalable filling machines, ideal for small to medium batch production environments.

Response Benchtop Filler

Adelphi manufactures the highly regarded Response benchtop volumetric filling machine, and can deliver reliable after sales support wherever you are in the world.

This pneumatically driven filler is suitable for filling liquids, creams or solids in suspension thanks to its versatile filling head design.

The Response is adaptable, accurate, hygienic and easy to use. It is available in single or twin-head configurations, with a comprehensive range of nozzles, hoppers and other accessories available to meet your individual requirements.

These machines are ideally suited to those wanting to start automating a previously manual filling process, and those that don't currently require the output levels offered by a fully automated solution. However, as production demands increase, Response units can be mounted onto our Monobloc Filler/Capper or Automation Base, to create an extremely flexible fully automatic filling solution.

Exceptional filling accuracy of +/-0.25% - a 75% improvement on the industry average of +/-1%



Left: heated hopper for hot fills.

Below: pipe feed attached, for liquid fills.

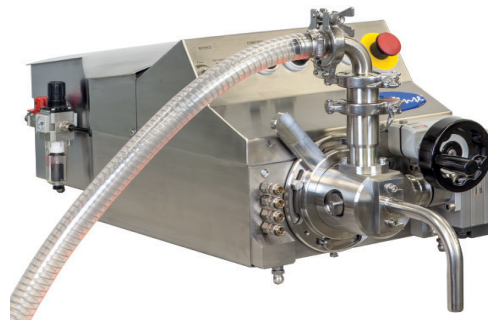

Above: with our standard hopper for filling liquids, oils, gels, creams, pastes, and solids-in-suspension

“Reliable, good solid pieces of equipment that have lasted. When we’ve looked at other cheaper machines, in the long-term this would have been false economy”.

Eve Taylor (London) Ltd



RESPONSE VOLUMETRIC FILLERS



Versatile & Accurate

The Response features a revolutionary head designed to handle liquids, creams, pastes, and solids in suspension efficiently. A variety of nozzle designs are available, including cut-off nozzles for a clean fill with no dripping. The forward and backward stroke can be varied independently to optimise filling characteristics, and it has the ability to fill volumes of 5ml to 1000ml, with an accuracy $\pm 0.25\%$, using one of three interchangeable honed pump sets.

Simple & Safe to Use

Volumes are accurately and easily set by means of a hand wheel and digital counter, and the unit can be set to single shot or continuous operation. All controls are within easy reach of the operator at the front of the unit, with a foot switch as an option. With quick-release fittings and the need for just a single tool, strip-down for cleaning is quick and easy. All access is from the front of the machine without the need to remove the cover, and all moving parts are enclosed at all times. The unit is fully CE Marked.



Hygienic

The Response is designed to minimise cleaning time and to meet the highest standards of hygiene. A 304 stainless steel monocoque construction with curved and sloping surfaces meets GMP requirements, and all contact parts are manufactured in 316L stainless steel, PTFE and Viton. The innovative pumping system is designed to be clean and lubricant free, and all hose/hopper connections are triclover as standard.

| | Specification | |
|------------------------------|-------------------|-------------------|
| MODEL | SINGLE HEAD | TWIN HEAD |
| Accuracy | $\pm 0.25\%$ | $\pm 0.25\%$ |
| Output (per minute) | < 40 | < 80 |
| Height without hopper / tank | 340 mm | 340 mm |
| Depth | 840 mm | 840 mm |
| Width without conveyor | 343 mm | 343 mm |
| Weight | 41 kg | 44 kg |
| Air consumption per cycle | 5 litres at 6 bar | 5 litres at 6 bar |
| Volume range | 5 ml – 1 litre | 5 ml–100ml |



Accessories

Standard Nozzles

A wide variety of interchangeable nozzles are available for different products. A remote nozzle for dosing into or over food etc. can also be supplied.

Special Nozzles

Cut-off nozzles for a clean fill with no dripping are available, and are attached to the Response using the same fixings as any other nozzle. They are pneumatically operated and powered through the accessory ports on the front of the machine.

Hoppers & Tanks

Available in 316L stainless steel and in standard 20 litre and 50 litre sizes, our hoppers can be supplied plain, insulated for cold products or electrically heated for hot fills. All are connected with hygienic Tri-Clover type fittings.

Counter

A counter attachment is available to control multiple shots.

Mixers & Stirrers

We can supply a variety of mixers and stirrers, free standing or lid mounted, in a variety of sizes.

Other Accessories

- Diving nozzles
- Remote cut-off nozzle
- Level control sensor fitted to hopper
- Spinning table for filling irregular shaped jars
- 2-speed filling system
- Stainless steel benches and trolleys
- Bag and pouch filling system





RESPONSE VOLUMETRIC FILLERS

Response

ATEX Filler



CAT II 2 G c T 5 (100 Degrees Celsius) automatic filling machine.

ATEX is the name commonly given to the European Directive for controlling explosive atmospheres. Our Response Filler can be adapted to comply with directive 94/9/EC (also known as 'ATEX 95' or 'the ATEX Equipment Directive') on the approximation of the laws of Members States concerning equipment and protective systems intended for use in potentially explosive atmospheres.

There are three zones relating to ATEX compliancy – Adelphi can adapt our Response base unit or automation system to be Zone 1 (10 – 1,000 hours per year in the explosive atmosphere) and Zone 2 (0 - 10 hours per year in the explosive atmosphere) compliant. We will provide the relevant documentation to support your purchase and ensure peace of mind.

Our standard Response machines are adapted to adhere to ATEX requirements, and are made with qualified pneumatic components. We engineer-out any possible sources of static build up, and we ensure good earthing via an Earth Point included at the rear. Materials such as stainless steel are used to replace some aluminium and plastic parts, and the machine is raised on different feet to allow grounding. Additionally, the hopper comes with a lid to reduce fumes.

Our ATEX adapted Response fillers can come with various seal and O-ring options, which we will assess to ensure compatibility with your product:

- Fluoroelastomer (VITON)
- EPDM
- Perfluoroelastomer (KALREZ)

We have lodged a technical file (09XT005) with an approved body.

Please note that our ATEX machines do not cover explosive risks from dust; only gas.



The Earth Point



ATEX compliant feet

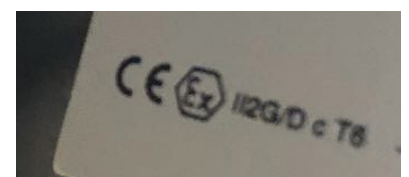

Look for the 'EX' mark for assurance that our parts are ATEX approved



Response

Monobloc Filler

Adelphi's Response Monobloc Filler provides many advantages for customers compared with traditional inline packaging systems.

Key features and benefits:

- Capable of filling 5ml to 250ml containers
- Space-saving design
- Ten-minute strip down time
- Hygienic stainless steel construction; all wetted parts are 316 stainless steel
- Response volumetric filler fill-accuracy +/- 0.25%
- Quick and easy to change parts from one fill-size container to another
- Easy-to-use intuitive HMI touch screen controls for your operator
- Designed to effectively handle liquids, oils, creams, pastes and solids in suspension
- Speed of operation in the region of 35 per minute
- Reduced labour costs



The Response Monobloc Filler can incorporate the following elements to give a complete turnkey packaging line:

- In-feed table
- Bottle blower
- Filler
- Automatic cap placement
- Capper
- Labeller
- Collection table

| | Specification |
|------------------------------|---|
| Accuracy | ±0.25% |
| Output (per minute) | 30 - 35 |
| Height without hopper / tank | 2032 mm |
| Depth | 810 mm |
| Width without conveyor | 1120 mm |
| Weight (approx) | 275 kg (plus Response base unit and hopper) |
| Air consumption per cycle | 7.5 litres at 6 bar |
| Volume range | 5 ml - 250ml |
| Electrical consumption | Single phase 240VAC, 13A supply |
| Maximum bottle diameter | 85 mm (outer diameter) |
| Maximum bottle height | 250 mm |
| Maximum cap diameter | 45 mm |

The Response Monobloc Filler has been designed to work with our Adelphi Response Volumetric Filler, but it can also be configured to incorporate fillers from other suppliers.

Suitable container dimensions:

External diameter up to 85mm
Height up to 250mm
Cap diameter up to 45mm



Response

Automation Base

Key features and options:

- Variable speed conveyor with adjustable guides, rails, and delrin or stainless steel slats
- Logic controls for gating and sensing systems and up to four Response fillers
- Neck location system
- Pneumatic cut-off nozzles to ensure a clean fill with no dripping
- ‘Rise while fill’ or ‘bottom up fill’ of container, into neck or fixed nozzle fill system
- Fully interlocked guarding around operating area
- Frame mounted hopper or tank with up to four triclover outlets, manifold and heated jacket
- Other bespoke additions depending on your requirements

| | Specification |
|------------------------------|---------------------|
| MODEL | AUTOMATION BASE |
| Accuracy | ±0.25% |
| Output (per minute) | Dependent |
| Height without hopper / tank | 1800 mm |
| Depth | 1070 mm |
| Width without conveyor | 1650 mm |
| Weight | 396 kg + Responses |
| Air consumption per cycle | 40 litres per cycle |
| Volume range | 5 ml-1 litre |



(Above) Automation Base with three Response units fitted; seen from the rear



Automation Base with three Response units fitted; operator's view from the front

“The machine can be adapted quickly to different fill sizes and container types, which benefits us greatly with the variety of products we fill. We also find the change parts on the machine really quick and easy to swap over when we change production runs, so we can keep the machine clean between fills with minimal effort”.

Barry M Cosmetics



Manual Cap Press

The Adelphi Cap Press is a bench top, hand operated, spring loaded machine designed to enable the easy fixing of press-on lids and caps to glass or plastic bottles. It has adjustable height and depth to accommodate a wide range of container heights and cap diameters.

This is a high quality bottle cap press, buy right and buy once.

| | Specification |
|-------------------------|------------------------------------|
| SP013-01 | MANUAL CAP PRESS |
| Output (per hour) | Up to 1,000 |
| Bottle size (mm) | Up to 100 diameter, up to 240 high |
| Overall dimensions (mm) | 250 x 250 x 450 |
| Operational weight (kg) | 10 |



Pneumatic Cap Press

The Adelphi Pneumatic Cap Press is a bench top machine, designed to enable the easy fixing of press-on lids and caps to glass or plastic bottles. It has adjustable height and depth to accommodate a wide range of container heights and cap diameters.

Incorporating an adjustable bottle locator and adjustable stop for press position, this Cap Press offers an approximate output of 6 – 10 containers per minute.

Constructed from hygienic and durable anodised aluminium and stainless steel.

Bespoke press pads to suit shaped caps can be made to suit your samples, for an additional charge.



400 - 500
bottles per hour

Pneumatic Capping Machine

The Adelphi Pneumatic Capping Machine is a bench top unit suitable for closing twist-off caps easily and with great accuracy. It is robust yet portable, very easy to operate, and low maintenance.

The machine is adapted to a wide range of cap sizes by changing only the cap chuck. Strong and reliable, this capper allows the operator to close around 400 - 500 bottles per hour. The closure torque is manually adjustable through mechanical friction.

| | Specification |
|-------------------------|----------------------------------|
| 8201000 | PNEUMATIC CAPPING MACHINE |
| Max bottle height (mm) | 320 |
| Torque range (NM) | 0.3 - 4 |
| Overall dimensions (mm) | 350 x 350 x 700 |
| Weight (kg) | 15 |



ROPP Capper

The Adelphi ROPP Capping Machine is a bench top unit suitable for applying aluminium ROPP caps.

The unit is fully adjustable in height using a hand wheel, and includes an electrical control panel with emergency stop and isolator, 4 roller capping head, bottle locator, safety guard and safety start buttons.

| | Specification |
|--------------------------------|-----------------------------|
| 8203000 | ROPP CAPPING MACHINE |
| Min/Max cap diameter (mm) | 15 / 50 |
| Max head loading pressure (kg) | 60 |
| Overall dimensions (mm) | 500 x 500 x 1000 |
| Weight (kg) | 40 |



INDUSTRIES WE SERVE

Pharmaceutical and Healthcare

We have excellent knowledge of the strict regulations that pharmaceutical manufacturers must adhere to, and of GMP standards. 'Wetted' product contact parts can all be supplied in 316L pharmaceutical grade stainless steel. The use of an X-ray analyser enables us to provide full traceability on all our materials, along with the relevant certification.

Cosmetics and Personal Care

Whether the products are exclusive to a luxury spa or hotel, or part of a high-volume range sold through multinational supermarkets, cosmetics and personal care product manufacturers can rely on us to supply the highest quality equipment and machinery.

Food and Beverage

All of our products are manufactured with food hygiene in mind; designed with crevice and pit-free surfaces to avoid bug traps. Our range of process machinery is ideal for food production environments where manufacturers require the highest quality.

Research and Laboratory

Our products are perfectly suited to use by researchers and laboratory technicians developing and producing liquid-based drugs. All our products conform to strict pharmaceutical regulations, and come with the necessary certification. Customers in this area cover the spectrum of life sciences and clinical diagnostics, striving to improve global healthcare, to create new life-saving treatments for hospitals, or to advance veterinary medicine.

E-Liquid & CBD Oil

Manufacturing and mixing processes in the production of E-liquids will benefit from the use of our high quality filling and capping machines. Our products are fully compliant with all new regulations applying to the mixing and blending of vaping oils with flavourings.

ADELPHI MANUFACTURING

Olympus House · Mill Green Road · Haywards Heath · West Sussex RH16 1XQ · UK

+44 (0)1444 472300

info@adelphi.uk.com

www.adelphi.uk.com

The Adelphi Group of Companies

Adelphi Manufacturing

Adelphi Manufacturing offers manual and semi-automatic equipment designed to aid the efficient opening, filling, closing and inspecting of a variety of containers such as capsules, ampoules, vials, syringes, tubes and bottles. It also offers a range of pharmaceutical dispensing equipment, and is the sole UK agent for TGM tube fillers and ROTA ampoule fillers.

sales@adelphi.uk.com
www.adelphi-le.com

Adelphi Masterfil

Manufacturers of filling and capping machinery, from single machines to complete turnkey lines. Adelphi Masterfil primarily serves the lube oil, chemical (including household and agrochemical), cosmetics and food industries.

sales@masterfil.com
www.masterfil.com

Pharma Hygiene Products

Pharma Hygiene Products is a leading supplier of high quality stainless steel process equipment, from standard utensils and containers, to custom designed mixing vessels to suit a number of manufacturing industries. All are made to pharmaceutical standards in 304 and 316L grade stainless steel.

info@pharmahygieneproducts.com
www.pharmahygieneproducts.com

Adelphi Healthcare Packaging

Suppliers of a comprehensive range of glass, plastic and aluminium containers, high precision dispensing systems, various closures including stoppers, crimp seals and screw caps as well as a range of boxes, held in stock ready for immediate dispatch worldwide.

sales@adelphi-hp.com
www.adelphi-hp.com



ADELPHI
MANUFACTURING



ADELPHI
Masterfil[®]



ADELPHI
PHARMA HYGIENE PRODUCTS



ADELPHI
HEALTHCARE PACKAGING



ADELPHI
MANUFACTURING

A personal approach, on a global scale

www.adelphi.uk.com